

Temperature Compensated Crystal Oscillator (TCXO/VCTCXO)

High stability
Ceramic Package
One chip IC

Pb-free : RoHs compliance

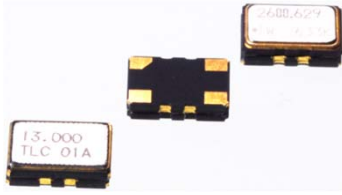

CO-SCH5032 , CO-SCH5032V

■ Typical applications

- Femtocell, Base Station, StratumIII

■ Features

- 10.000 to 52.000 MHz.
- High Stability(± 0.20 ppm /-40 ~ +85° C) ,Low Aging(± 0.5 ppm/Year)
- Low Load Chang(± 0.05 ppm), Low Supply Voltage Chang(± 0.05 ppm)
- Miniature type essential in the high density PCB.
- Package : Metal lid + Ceramic package.

5.0×3.2×1.5mm

■ Specifications

Model		CO-SCH5032	CO-SCH5032V
Available Frequency Range		10.000 to 52.000 MHz	
Frequency Stability	Tolerance (at 25° C)	± 0.5 ppm	
	Temperature(Ref. to 25° C)	± 0.20 ppm max. (-40 to +85° C) ± 0.05 ppm max. (-10 to +70° C)	
	Supply Voltage Change	± 0.05 ppm (Vcc $\pm 5\%$)	
	Load Change	± 0.05 ppm (Load $\pm 10\%$)	
Power Supply Voltage		+2.7V to 5.5V	
Power Supply Current		2.4 mA max.	
Output	Voltage	0.8 Vp-p min.	
	Load	10 K Ω // 10 pF	
	Waveform	Clipped Sine Wave (DC No Coupled)	
External Control Function		-	± 3.0 to ± 15 ppm / +1.5 ± 1.0 V DC
Storage Temperature Range		-40 to +85° C	
Phase Noise		-135 dBc/Hz max (at 1KHz)	

■ Environmental Characteristics

Description	Specification
Aging (at 25° C)	± 0.5 ppm max / Year (at 25° C)
Fall Shock	Test : 3 time free drop onto concrete board from 150cm high Result: ± 1.0 ppm max.
Vibration Shock	Test : Freq. 5-500Hz, Amplitude 1.5mm, Test time 4cycles/XYZ axis Result: ± 1.0 ppm max.
Solderability	Test : Immersed into solder bath at 235 \pm ° C for 3 sec. Result: More than 95%
Humidity	Test : 90 to 95%RH at 60 ± 3 ° C ± 500 hours Result: ± 1.0 ppm max.
Reflow Heat	Test : 2 times of IR reflow soldering in accordance with reflow temperature profile as per the document No.:TR-0531 Result: ± 1.0 ppm max.

■ Outline Drawing & Suggested Pad

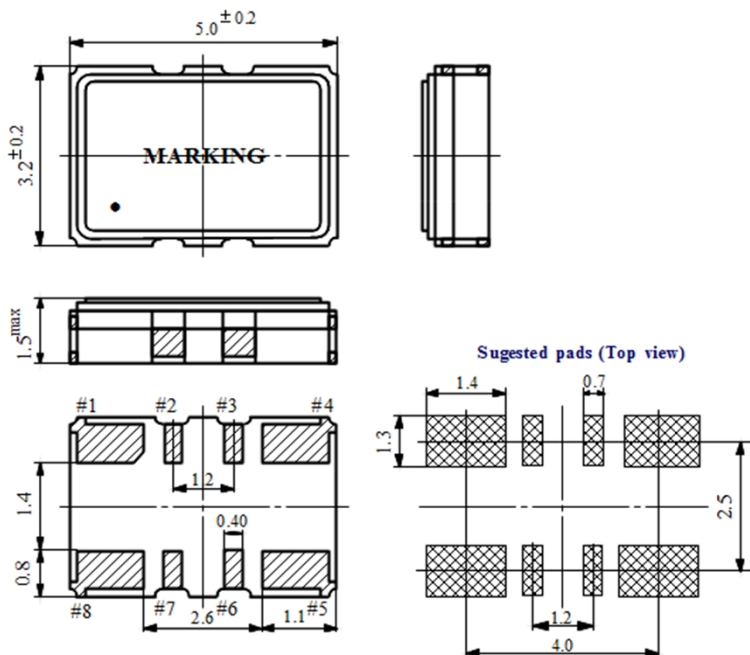

TERMINAL	CONNECTION	
	TCXO	VCTCXO
#1	GND	Vcont
#2	NC	NC
#3	NC	NC
#4	GND	GND
#5	OUTPUT	OUTPUT
#6	E / D *1	E / D *1
#7	NC	NC
#8	Vcc	Vcc

*1 : Please connected to Vcc or unconnected if not required