

● TAPE (mm)

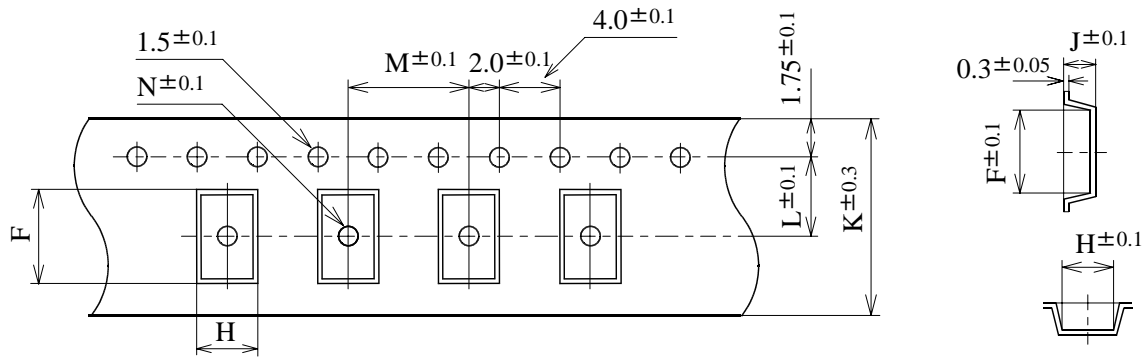

MODEL	F	H	J	K	L	M	N
MC - 3030	3.2	3.2	1.5	8.0	3.5	4.0	1.05
MC - 3838	4.25	4.25	1.35	12.0	5.5	8.0	1.55
MC - 7050	7.5	5.5	1.8	16.0	7.5	8.0	1.55

● REEL (mm)

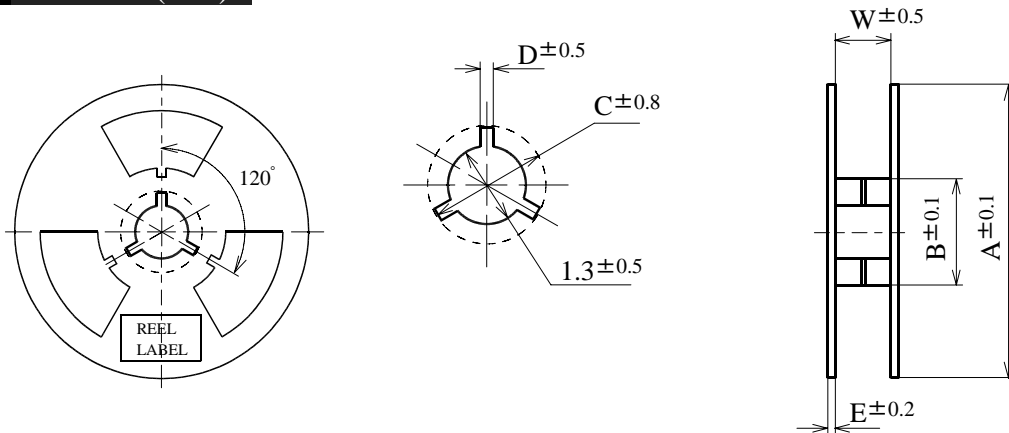

MODEL	A	B	C	D	E	W
MC - 3030	180	60	21	2.0	1.7	9.0
MC - 3838	180	80	21	2.0	1.5	13.5
MC - 7050	180	100	21	2.0	2.0	17.5

APPROVE	DESIGNED	PUBLICATIO	21 / 03 / 2001	ITEM	OUTLINE AND DIMENSION (MCF)
		REVISION			
		REVISION			
		REVISION			
				DRW.No.	TT - 0531

● TAPE (mm)

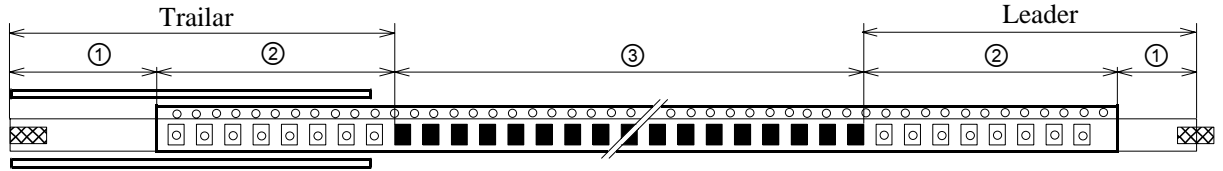

- ① Only top of tape 250min.
- ② Empty tape 150min.
- ③ Mounted the part in the tape

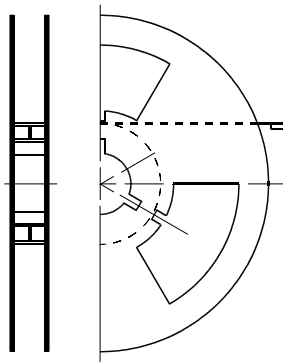

- 1) Rolling direction of taping on reel is clock-wise as above figure.
When pulling the edge of the tape, the hole is right side.
- 2) Top of leader is fixed with the roller tape by adhesive tape
- 3) Direction of installation is above figure

● Reel Label

P/O No.	
Model	
Frequency	
Quantity	

APPROVE	DESIGNED	PUBLICATIO	21 / 03 / 2001	ITEM	OUTLINE AND DIMENSION
		REVISION			
		REVISION			
		REVISION			
				DRW.No.	TT - 052XA